

Light Diffuser Plates for LCD-TV Backlight Systems

Sumitomo Chemical Co., Ltd.

IT-Related Chemicals Research Laboratory

Akiyoshi KANEMITSU

Takashi SAKAMOTO

Hironobu IYAMA

A lighting system called direct type is usually employed for backlight systems in large size LCD-TVs. With this type of backlight system, a diffuser plate has to be mounted in order to blur the images of CCFLs and to hold several thin optical films. We have developed diffuser plates with properties which are specially optimized for this type of backlight system, and have released them onto the market. In this report, the properties that are required for diffuser plates and our R&D activity will be described.

This paper is translated from R&D Report, "SUMITOMO KAGAKU", vol. 2007-I.

Introduction

The demand for television sets known as flat-panel displays (FPD) is expected to grow rapidly as shown in Fig. 1-a). What type of FPD will be dominant is still controversial, there are strong expectations for LCD-TVs to be the market leader restraining other types of FPD like PDPs and projection TVs. At the same time, looking at it by size as shown in Fig. 1-b), the growth in 30 inch or larger size, particularly 40 inch class size will be remarkable, and there is an overall movement toward larger size.

On the other hand, because liquid crystal displays do not emit the light by themselves, several light sources that illuminate the liquid crystal panel from its backside are necessary. This is what we call backlight sys-

tems. Sumitomo Chemical marketed a diffuser plate, which is set into these systems in 2001, ahead of other companies, and with further improvements, continues to maintain the largest share of the market to date.

In this article, general properties that are required for the diffuser plates specially designed to adjust to the LCD-TV sets will be described. Then, some of the latest issues that have emerged from the demand for much larger size and cost reductions will also be discussed.

Liquid Crystal Display Structure and Diffuser Plates

As shown in Fig. 2, there are several types of backlight systems that are used in liquid crystal displays



Fig. 1 Worldwide development of the number of TV set
[Quoted from reference 1) and 2)]

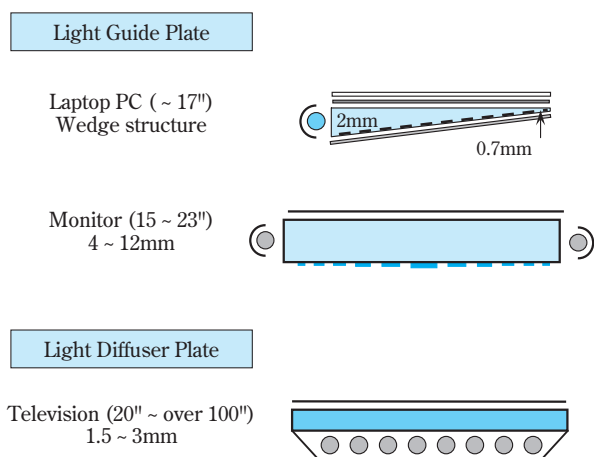

Fig. 2 Typical configuration of backlight systems for various types of liquid crystal displays

according to the size of the display. For applications like laptops and PC monitors, illumination systems known as “edge lit” are usually used. In these systems, linear light sources (normally Cold Cathode Fluorescent Lamp; CCFL) are placed at the edges of a highly transparent plastic plate called a light guide plate, within which the light propagates from one edge to the other edge in accordance with the TIR (Total Internal Reflection). White dots printed on the opposite surface to the emission surface scatter the light uniformly by adjusting the dot density.

On the other hand, in larger displays like LCD-TVs, a large number of CCFL are required depending on the size of the screen to assure sufficient luminance. Since the number of CCFLs that can be accommodated in an edge is limited, an illumination system known as the “direct type” backlight system is adopted, where the illumination comes from directly behind the liquid crystal panel from multiple CCFLs. In this system, the images of the light sources can be seen through the panel as shown in Fig. 3-a). Therefore, a white opaque plate, called a diffuser plate, with a thickness of several millimeters is installed to hide the images of the light sources. Finally, as is shown in Fig. 4, several types of optically functional films, such as a diffuser film, prism film and brightness enhancement film, are used together with a diffuser plate in order to adjust the final optical performance.

Needless to say, the properties of the diffuser plate greatly influence the actual performance of the TV set, so that the requirements for diffuser plates are high in regards of mechanical properties, durability and the like, in addition to the basic optical properties.

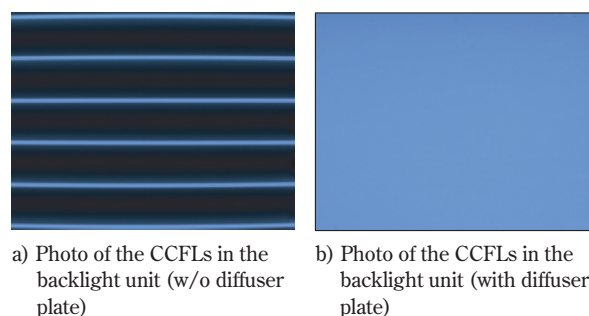

Fig. 3 Basic function of the light diffuser plate (CCFL = Cold Cathode Fluorescent Lamp)

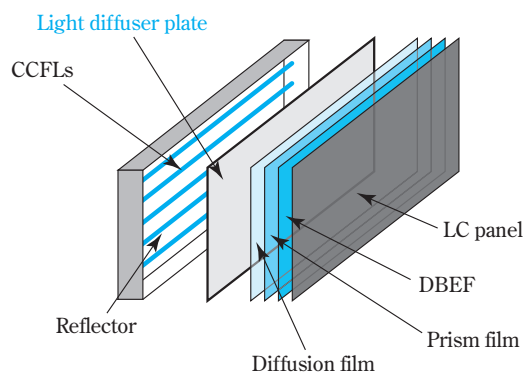

Fig. 4 Typical configuration of the direct type backlight system

Optical Characteristics

Diffuser plates that are made from transparent resin usually contain some fine particles known as light diffuser agents in order to obtain sufficient diffusivity. This diffusivity largely depends on the difference in refractive index between the particle and the matrix, and the diameter of the light diffuser agent. Assuming that the shape of a light diffuser agent is spherical, the diffusing performance due to a single diffuser agent particle can be determined by using the Mie scattering theory. For example, Fig. 5 shows two examples of calculated angular dependence of scattered light when the particle diameter is the same but their refractive indices are different. While the intensity of the scattered light in the forward direction is approximately the same, we can see that the intensity at wider angles and back scattering are much stronger for particles with a larger refractive index difference compared to those with a smaller refractive index difference. However, since the diffusing agent particles used in actual diffuser agents are naturally not single particles, the effect of multiple scattering must be considered, and in addi-

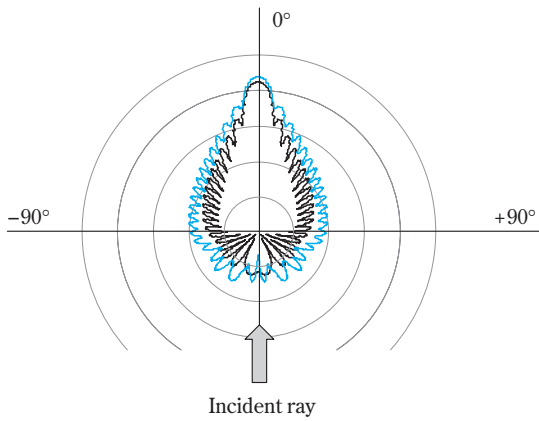

Fig. 5 Calculated Mie scattering diagrams of two particles with different refractive indices. n of matrix is 1.50, n of particle is 1.55 and 1.60 for black line and blue line, respectively

tion, there is a wide size distribution in most cases. Therefore, accurately predicting the light scattering characteristics for diffuser plates in backlight systems is quite difficult. Nonetheless the calculation of scattering characteristics of a single particle by using theories, like the Mie scattering theory, is very valuable for selecting materials for diffuser plates.

Total light transmittance (Tt) and diffusion factor (D) are usually used as indices in order to estimate the light diffusing properties of diffuser plates. Total light transmittance is provided for in JIS7361, and it is a ratio of the light transmitted in the forward direction and the incident light. On the other hand, the diffusion factor is a value determined from the angular dependence of the transmitted scattered light when the diffuser plate is illuminated with collimated light. from the perpendicular direction. The equation shown in Fig. 6 is used to determine the diffusion factor using the intensity at 5, 20 and 70 degree. The total light transmittance and the diffusion factor can be controlled mainly by changing the type and concentration of the light diffuser agent.

Fig. 7 shows an example of the relationship between total light transmittance and the diffusion factor for a diffuser plate where the difference in the refractive index for the matrix resin and the light diffusing agent and the particle diameter are changed. For example, even if the value for the total light transmittance is the same, a diffuser plate with a different value for the diffusion factor can be obtained by changing the matrix resin and the type of light diffusing agent. The final performance depends on the backlight unit structure and configuration, however, materials that have much

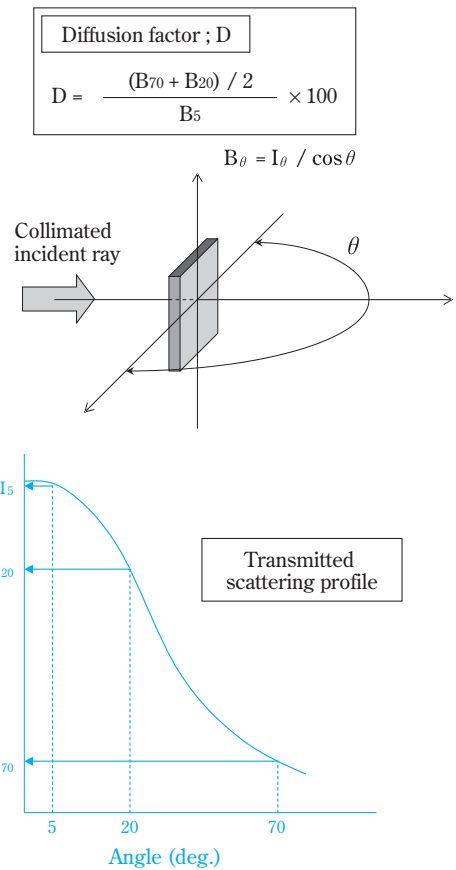

Fig. 6 An example of the transmitted scattering profile of a diffuser plate and the definition of Diffusion Factor (D)

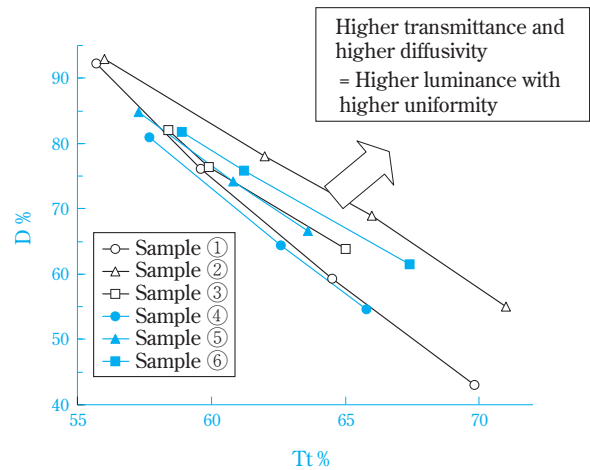
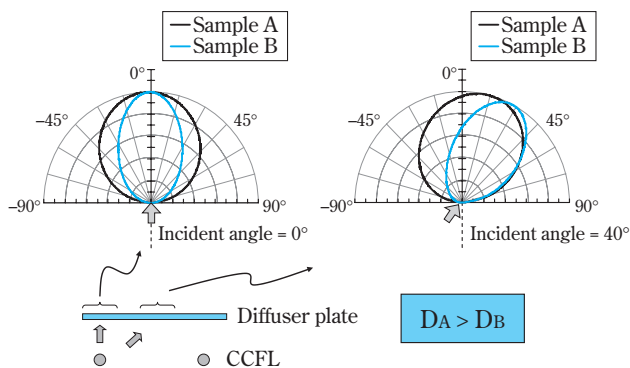

Fig. 7 Some examples of Tt-D balance curve obtained from some particles with various diameters and refractive indices

higher total light transmittance with a high diffusion factor tend to have a much higher performance from the standpoint of efficient use of the light.

Fig. 8 shows an angular distribution for transmitted scattered light when light is incident to two diffuser

plates with different light transmission and scattering properties from the normal line direction and from an off axis direction. When the light is incident from the normal line direction, both the behavior of the light incident in the vicinity directly in front of the light source and the behavior of the light incident in positions between light sources when the incident angle is slanted can be estimated. Diffuser plates, which have the characteristic of increasing the luminance in the dark area between the two adjacent light sources while suppressing the luminance of the area where the image of the light source appears strongly as in the neighborhood directly in front of the light source, can be said to be suitable for backlights with a high level of uniformity. Sample A is a diffusion plate with a diffusion factor greater than that of Sample B, but the light incident from the perpendicular direction is more strongly scattered than Sample B, and the orthogonal component of the transmitted scattered light is greater than the light that is incident from the off axis direction.



Sample A ; $T_t = 55\%$, $D = 90$,
Sample B ; $T_t = 65\%$, $D = 60$.

Fig. 8 Transmitted scattering diagrams of two different diffuser plates with different T_t and D

In order to optimize the optical properties of diffuser plates, an estimation of scattering properties by using the Mie scattering theory and measurement of total light transmittance and diffusion factor are generally carried out in advance. As described above, however, it is very difficult to predict the final optical properties of backlight systems because the actual configuration of a backlight system is not so simple. Therefore, sometimes simple model systems are used to finalize the composition and the structure of diffuser plates. For example, a small backlight unit with a black absorber

behind the CCFLs to eliminate the external influence. Fig. 9 shows an example of a result that was obtained with this simplified backlight unit. The luminance v. s. uniformity balance curves for diffuser with two sets of materials with two types of diffuser agents with different refractive indices which were added into the same base matrix resin are shown. The difference in the luminance performance due to the types of the diffuser agent can be predicted much better by using this method. Although, customers finalize the structure and the configuration of the backlight unit, the data obtained by the method described above is useful when introducing our diffuser plates to our customers.

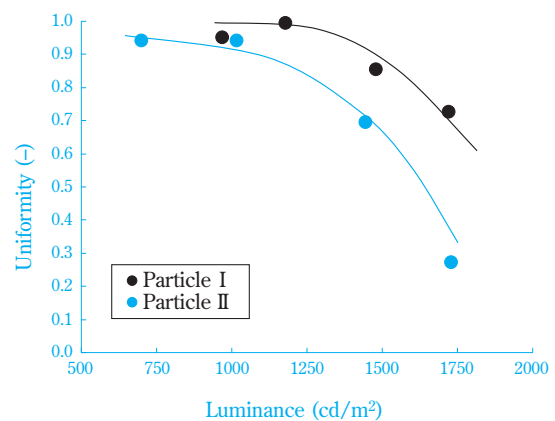
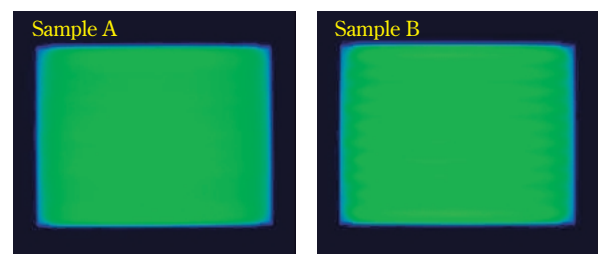

Fig. 9 Some examples of the luminance performance using a model backlight unit

Fig. 10 shows some examples of the images of the backlight units in which the sample A and B, described above, were installed. CCFL images were not recognized for sample A due to higher diffusion factor, whereas some CCFL images were observed for sample B, although luminance was much higher than sample A



Sample A ; $T_t = 55\%$, $D = 90$, No CCFL image was observed.
Luminance 6030 cd/m^2

Sample B ; $T_t = 65\%$, $D = 60$, Some CCFL images were observed.
Luminance 6350 cd/m^2

Fig. 10 The images of the CCFLs observed through Sample A plate and B plate

due to higher total light transmittance. From this result, it can be said that luminance and its uniformity highly depend on the configuration of CCFLs, that is, the distance between adjacent two CCFLs and the space between CCFLs and the diffuser plate. For example, for the backlight where the space between two adjacent CCFLs is small, the diffuser plate with high total transmittance and low diffusion factor may be selected, otherwise diffuser plates with low total transmittance and high diffusion factor may be selected for the backlight where the space between two adjacent CCFLs is large.

We have arranged four main grades with different total light transmittance for the customers to select the diffuser plate with the properties that are suitable for their own backlight systems (Table 1).

Reliability

1. Light stability

As shown in Fig. 4, the space between diffuser plate and CCFLs is very small, usually only a little more than 10 millimeters. Although the intensity of the UV light emitted from CCFLs is quite low, diffuser plates sometimes get colored after an exposure over a long period of time. Therefore, the chromaticity of the image on the panel may change slightly. In general, UVCON or other common equipment is used to evaluate the dura-

bility of plastic materials. However, in order to obtain much more reliable results, we are using a mercury vapor light source whose UV spectrum is almost the same as that of CCFLs used in backlight systems as shown in Fig. 11.

Furthermore, for selection of UV absorbing agents a spectral radiation tester is used. For this test method,

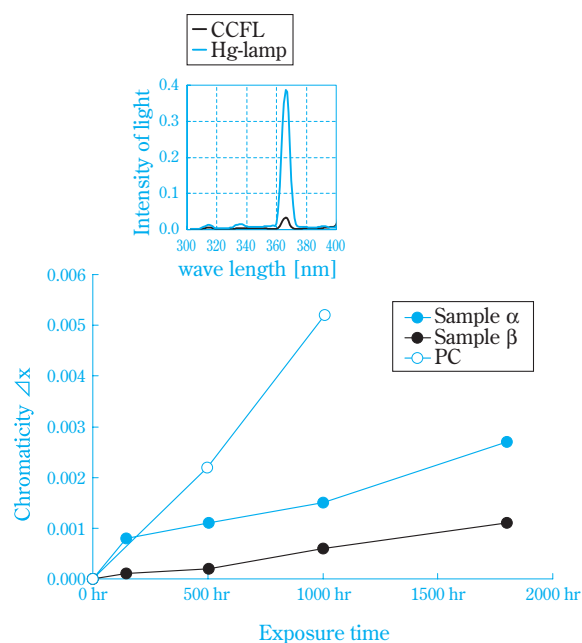

Fig. 11 Some examples of the UV (Hg lamp) exposure test results for various kind of base resin with different additives

Table 1 General properties of our diffuser plate

| Test Item | Unit | Method | RM80XS |
|--------------------------------------|-------------------|------------|--|
| Thickness | mm | - | 2 |
| Light Transmittance | % | JIS K 7361 | RM801S = 55 RM802S = 60 RM803S = 65 RM804S = 70 |
| Haze | % | JIS K 7163 | 99 |
| Gloss | % | JIS Z 8741 | 4 / 7 |
| Diffusion factor | % | SCC method | RM801S = 93 RM802S = 76 RM803S = 59 RM804S = 41 |
| Tensile Strength | MPa | JIS K 7113 | 38 |
| Tensile Elongation | % | JIS K 7113 | 2 |
| Tensile Modulus | GPa | JIS K 7113 | 3 |
| Flexural Strength | MPa | JIS K 7203 | 92 |
| Notched Izod Impact Strength | kJ/m ² | JIS K 7110 | 1.6 |
| Heat Distortion Temperature (18.6kg) | °C | JIS K 7207 | 91 |
| Scratch Hardness (pencil method) | - | JIS K 5600 | 2H |
| Surface Resistivity | Ω | JIS K 6911 | 10 ⁹⁻¹¹ |
| Coefficient of Linear Expansion | / °C | JIS K 7197 | 7 × 10 ⁻⁵ |

the wavelength of the light changes gradually so that the wavelength that causes the color change can be identified. This information helps us to select the most effective UV absorbing agent that does not have any negative effect on the optical properties. Then the UVA formulation is finalized after confirming the durability by exposure to the light from a mercury vapor lamp.

2. Anti-static treatment

In order to reduce the adhesion of the dust on the surface of components in the backlight units during the assembly, anti-static treatment may be applied to each component. We usually apply anti-static treatment to the surface of our light diffuser plates.

There are mainly two conventional methods to obtain anti-static properties. One is mixing the anti-static agent, into the base plastic resin for reducing the surface resistance. The other is coating the surface of the light diffuser plates with anti-static agent. The former has excellent durability with low anti-static effects. On the other hand, the latter shows excellent anti-static effects with a low durability. We have developed a new method for good anti-static effects over a long period of time by carefully selecting the anti-static agents and optimizing the application procedure. Fig. 12 shows that our new method is better for improving the long term anti-static effects under light exposure from a mercury vapor lamp.

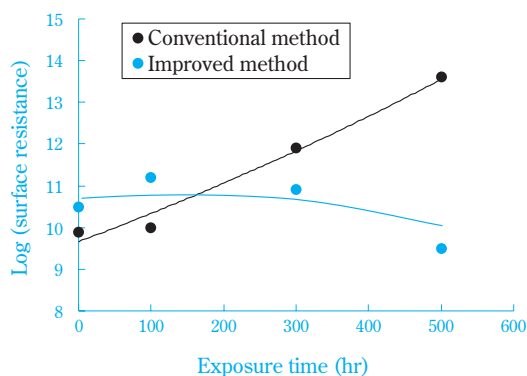

Fig. 12 Hg lamp exposure test for the diffuser plates with different types of anti-static treatment

Mechanical Characteristics

The diffuser plate has to have a suitable rigidity in order to hold several sheets of optical films as shown in Fig. 4. The space between the LC panel and the dif-

fuser plate should be kept uniform and the diffuser plate should not be warped toward the panel in order to reduce the unwanted Mura image.

The history of our development of diffuser plates is shown in Fig. 13. For the RM400 series, which are our earliest grades, the Mura image due to the imbalanced moisture absorption and drying property was one of the largest issues that is attributed to the moisture absorption property of the base resin, PMMA (Poly-methyl methacrylate).³⁾ After examining the materials for base resin with much lower moisture absorption, we developed and marketed the RM80XS series utilizing the styrene based resin.

Generally speaking, the light stability of polystyrene is lower than that of PMMA despite preferable property of moisture absorption. However, as a result of our research on light stability described above and optimizing the structure, we achieved well-balanced performance with low moisture absorption and excellent light stability.

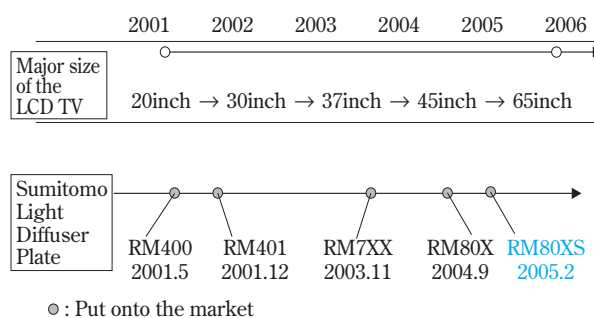

Fig. 13 The history of our development of diffuser plates for LCD-TVs

Fig. 14 shows the actually measured warpage trends of some diffuser plates built in the 37-inch size backlight unit. These diffuser plates were kept in a chamber at 60°C and 50% humidity for five days before starting the evaluation. "0 hour" in Fig. 14 means the time when the light sources were turned on, and the shift of the plate center, which means the displacement at the center point of the plate along with the normal line, was measured with the laser displacement gauge as shown in the picture of Fig. 14. For the conventional diffuser plates that are made from acrylic resin or polycarbonate, large displacement towards the LC panel side was observed. This is attributed to the imbalance of the removal of water. The removal of water from the CCFL side is much faster than on the other side due to the

higher temperature caused by the heat from the CCFLs. On the other hand, the RM80XS series, which is made from polystyrene based material, showed little displacement. We believe that this is attributed to its lower moisture absorption and higher moisture permeation than other conventional diffuser plates. Some examples of Mura images observed through LC panel are shown in Fig. 15. No Mura image was recognized for RM80XS series while clear white ring like patterns were observed for diffuser sample C of which moisture absorption and permeation property was not optimized.

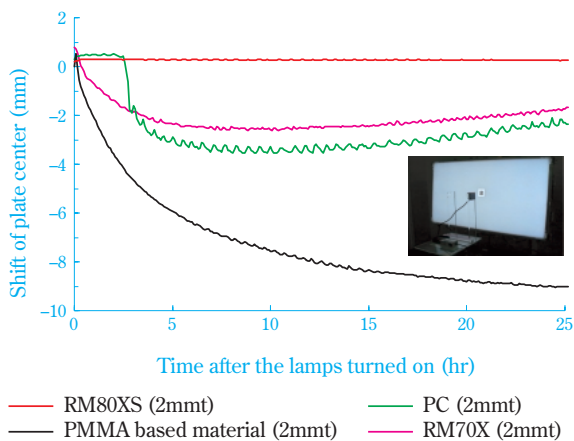

Fig. 14 Curl behavior of diffuser plates under illumination of CCFLs in backlight unit. Moisture adsorption ; RM80XS = 0.1%, PC = 0.4%, PMMA = 1.9%, RM70X = 0.3%



a) Sample C (2mmt)



b) RM804S (2mmt)

26 inch TV set.
16 hours later, after being kept in the chamber of which temperature was 50°C and humidity was 80%.

Fig. 15 Example of Mura test result

Latest trends and new approach for diffuser plates

1. Heat resistant diffusion plates

The requirement of heat resistance for diffusion plates has never been a critical issue to date, nevertheless we have developed new diffuser plates that have higher heat resistance with the view to the increasing of size of TV sets. There is still uncertainty over how high temperature the diffuser plate has to be stable, many more CCFLs may be built in to the much larger size LCD-TVs to raise the temperature inside of the TV sets especially around the inverters. It is thought to be of importance to develop heat resistance diffuser plates a head of the demand from the market in the future.

Fig. 16 shows the highest temperatures of each point at the surface of a diffuser plate built into the 46-inch backlight unit after placing it in the chamber of 55°C which is an unusual condition. As a result, it was confirmed that the temperatures at several points near the inverters were slightly over 80°C. In this measurement, where one of RM80XS was used, no distortion or warpage was observed at the area where the temperature was not higher than 80°C, while just a little distortion was observed in the area where the temperature was over 80°C. From this result, it was confirmed that the RM80XS series has sufficient heat resistance for ordinary conditions with temperatures not exceeding 80°C during normal use. For an environment with temperatures exceeding 80°C, our heat resistance diffuser plates are recommended as described in a later section.

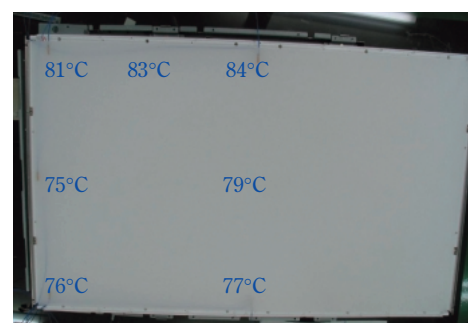

Fig. 16 Distribution of the maximum temperature (Size of backlight unit = 46inch, Chamber temperature = 55°C)

Fig. 17 shows the results of a heat distortion test where a strip of diffuser plate sample (150mm × 25mm) was set in the chamber with its one end held and kept

at a given temperature. From the displacement of the loose end of the strip sample, the tolerance against the temperature can be estimated. The heat resistant grade showed much smaller distortion at 90°C than the RM80XS series, although it was slightly more distorted compared to polycarbonate based samples with a higher glass transition temperature than our materials. Although still under development, we already got some approvals from customers.

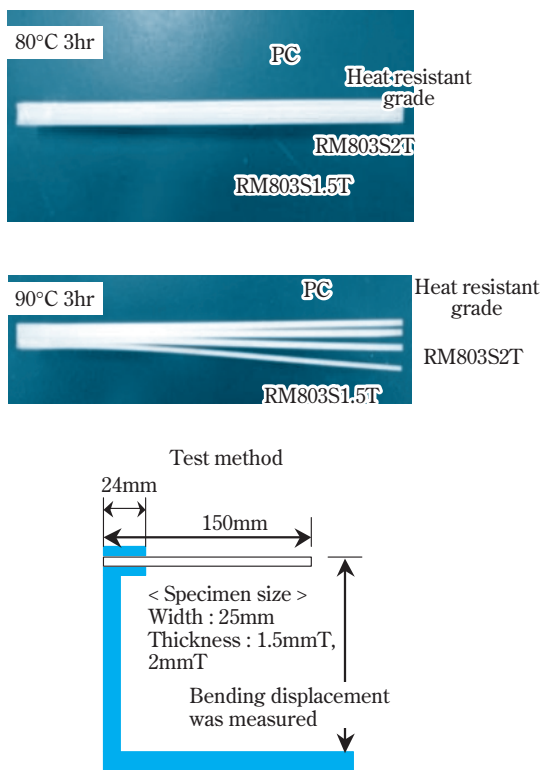

Fig. 17 Heat distortion test performed at 80 degree and 90 degree

2. Highly functionalized diffuser plates for higher luminance

As is mentioned before, several optical films are stacked on a diffuser plate in backlight unit systems in order to obtain sufficient luminance and its uniformity. However, these optical films contribute to a cost increase of backlight units so that lots of companies and researchers are trying to eliminate them without sacrificing the optical performance.

Careful study of the function of each optical film is necessary in order to eliminate them and figure out how their functions are combined with diffuser plates. First of all, we measured the total flux emitted from the backlight unit by using the large size integral sphere installed with a spectrometer. As a result, it turned out

that setting the diffuser plates did not reduce the total flux emitted from the CCFLs as shown in Fig. 18. In addition, the combination of a diffuser plate, a diffuser film, and a prism film reduces less than 10 % of the initial flux. This result means that the amount of the light that is lost by passing through the diffuser plate is negligible small so that we think it is not an effective way to replace the material with other optically low loss materials in order to increase the efficiency.

Next, we examined the angular dependence of the luminance emitted from the backlight unit. The result is shown in Fig. 19 where the abscissa axis indicates the angle from the normal line and the longitudinal axis indicates the luminance. Fig. 19-a) shows the luminance profile for the backlight unit with only the diffuser plate. The luminance in the range of -60 degree to +60 degree is almost the same so that the function of diffuser plates turned out to be scattering the incident light uniformly in a wide angle. On the other hand, as

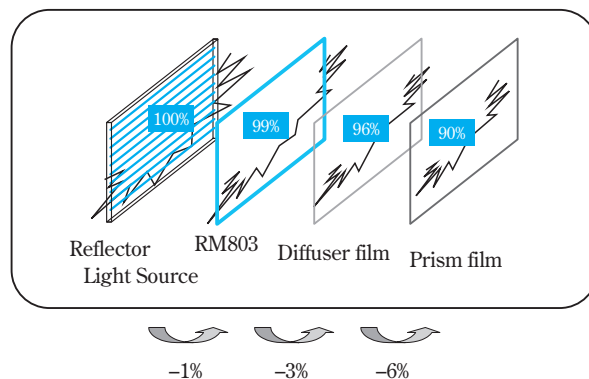

Fig. 18 Flux measurement of the 20 inch size LCD TV backlight system

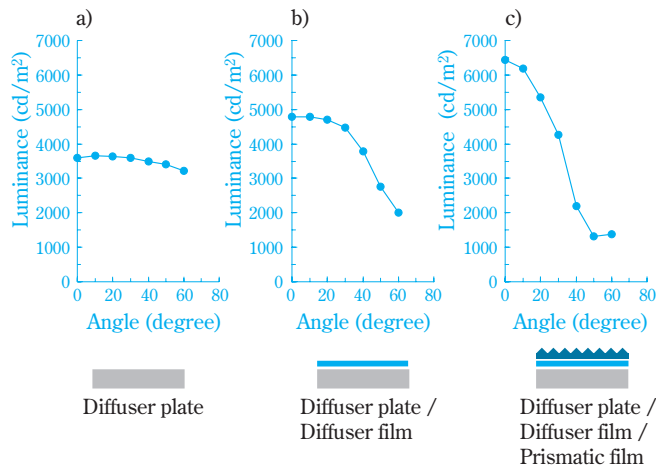

Fig. 19 Luminance profiles of three different types of optical film components

shown in Fig. 19-b), the emitted light was somewhat gathered toward the direction of the normal line. Usually, the diffuser film is a thin film coated with small particles with some binder material so that the basic function of diffuser film is to scatter the light. However, if the incident light is not collimated but rather scattered, this film functions as a light collimator, hence the luminance at the normal line increases by setting the diffuser film on the diffuser plate. Fig. 19-c) shows the luminance profile for the combination of a diffuser plate, a diffuser film and a prism film. As is understood from its name, brightness enhancement film, the prism film increases the luminance at the normal line by gathering the scattered light. Finally, the luminance at the normal line reached 180 % of the initial luminance with only a diffuser plate.

From the examination described above, we think that bending the direction of the emitted light in the direction of the normal line is a more practical method to combine all the functions of several optical films with a diffuser plate than trying to increase the total amount of emitted light. The simplest method to bend the direction of the emitted light is to form structures within or on the surface of the diffuser plate utilizing the refraction and reflection of light. However, the effect of light scattering by small particles must be incorporated with the effect of the structure in order to adjust the final optical performance, that makes the prediction with the simulator much more difficult. For example, the accuracy of the ray tracing simulation for an opaque object must be improved. In addition to the approach from the viewpoint of designing the structures, manufacturing processes for replicating the designed structures must be developed. Many new technologies for a precise microstructure are being proposed, but at this point, it seems to be difficult to apply these technologies to much larger areas than 40-

inch or larger size LCD-TVs without sacrificing the cost performance. Despite the technological trend described above, each manufacturer, including Sumitomo Chemical, is trying hard to produce surface structured diffuser plates with various manufacturing processes.

Conclusion

The diffuser plate is something very simple in its structure, made from transmissive base resin and small particles, the optical system of a backlight units is quite complicated so that obtaining well-balanced optical characteristics is extremely difficult. Research and development activities with a theoretical approach as well as approaches by utilizing the knowledge obtained from experiments and experience will be necessary.

In order to meet strong demand for cost reduction and higher optical performance, optimizing the reliability and mechanical properties through technologies on polymer materials and additives as well as polymer processing will be required. We will continue our efforts to develop unique and high performance diffuser plates with high customer satisfaction.

Reference

- 1) "Nikkei Market Access, Display market overview 2006", Techno System Research, Nikkei Market Access, Nikkei BP Consulting (2006), p.97.
- 2) "Nikkei Market Access, Display market overview 2006", Techno System Research, Nikkei Market Access, Nikkei BP Consulting (2006), p.36.
- 3) Kenji Manabe, Kazuhiro Yamazaki, Yoshiki Nishigaki, Tomohiro Maekawa, SUMITOMO KAGAKU, 2002-II, 15 (2002).

PROFILE



Akiyoshi KANEMITSU

Sumitomo Chemical Co., Ltd.
IT-Related Chemicals Research Laboratory
Senior Research Associate



Hironobu IYAMA

Sumitomo Chemical Co., Ltd.
IT-Related Chemicals Research Laboratory
Senior Research Associate



Takashi SAKAMOTO

Sumitomo Chemical Co., Ltd.
IT-Related Chemicals Research Laboratory
Senior Research Associate