Plastic Product Design using CAO (Computer Aided Optimization) Technique

Sumitomo Chemical Co., Ltd.
Petrochemicals Research Laboratory
Yoshiaki TOGAWA
Tomoo HIROTA
Shinichi NAGAOKA

Plastic CAE (Computer Aided Engineering) is used as indispensable technology in the plastic product design today. However, by integrating CAE technology and the CAO (Computer Aided Optimization) technology in which utilization has started, the automatic optimal design of a plastic product is attained and much more shortening the period of a product design, reducing development cost, and improving the quality and the performance of a product can be expected. Moreover, it becomes the powerful support technology of material development. In this paper, the outline of the integrated technology of the plastics CAE and CAO that we have developed, some application examples, and the integrated design optimization system for the plastic products of our company are described.

This paper is translated from R&D Report, "SUMITOMO KAGAKU", vol. 2004-II.

Introduction

Plastics are used in a variety of applications, such as parts for automobiles, consumer electronics and audio-visual equipment, as well as foodstuffs and packaging. The problems that are common to these various production industries is shortening the period for product development, reducing production costs, improving product quality and performance and handling environmental problems and safety problems. Currently plastic computer aided engineering (CAE) is used as one of the basic engineering techniques for achieving results with these problems.

On the other hand, with the rapid progress in computers and the developments in software technology recently, computer aided optimization (CAO)^{1), 2)} has reached a practical level, and it has gotten attention recently in various production industries. Since practical general purpose CAO support software has been marketed,³⁾ it has also become possible to use it plastic product design. CAO is the technology that uses computers for automation, optimization and integration. By integrating CAO technology and conventional CAE technology, the repetitive manual work for optimizing designs using CAE can be automated, and further, the differences in design quality due to the knowledge,

experience and skill of the operator can be reduced. We can expect that the development time for plastic products will be greatly shortened, efficiency increased and quality and performance improved.

Having passed through the first generation (advent – development) of plastic CAE technology in the 1980s and the second generation (maturing) in the 1990s, we are progressing toward the era of automation, optimization and integration (third generation) of CAE using CAO in the 2000s.

Sumitomo Chemical has been moving forward with the construction of third generation plastic CAE technology since 2000. In this paper, we will describe the status of development in this technology at Sumitomo Chemical.

Plastic CAE Technology

CAE is "the supporting of the analysis and simulations used in engineering using computers in the process of development and design of products,"⁴⁾

In the development of plastic products, plastic computer aided engineering (CAE) is used in product and mold design, the molding process, and further, in the stage of evaluating product performance.

Plastic CAE is composed of the mechanical CAE

developed for use with conventional metal materials and various types of molding CAE developed especially for polymers. Mechanical CAE has technology for structural analysis, impact analysis, vibration analysis and the like for evaluating static and dynamic mechanical characteristics, but there is a need to develop the technology for use with polymer materials. On the other hand, in molding process CAE, specialized software has been developed for injection molding, blow molding, extrusion molding and various other types on molding processes. Using these, it is possible to simulate the behavior and history of the changes in state for melting, cooling and hardening of polymer materials during the molding process, and further, the appearance, quality and performance of the product after molding based on the dilution history, and this can be used in analysis and evaluation.

Sumitomo Chemical has been developing plastic CAE technology for more than 20 years as one of the basic technologies for molding processes, and it has been applied in (1) supporting customer product and mold design, supporting clarification and measures for bad molding phenomena and the like, (2) supporting Sumitomo Chemical's materials development and (3) supporting the development of plastic products at Sumitomo Chemical and related companies.⁵⁾⁻⁸⁾ **Fig. 1** shows the Sumitomo Chemical plastic CAE system.

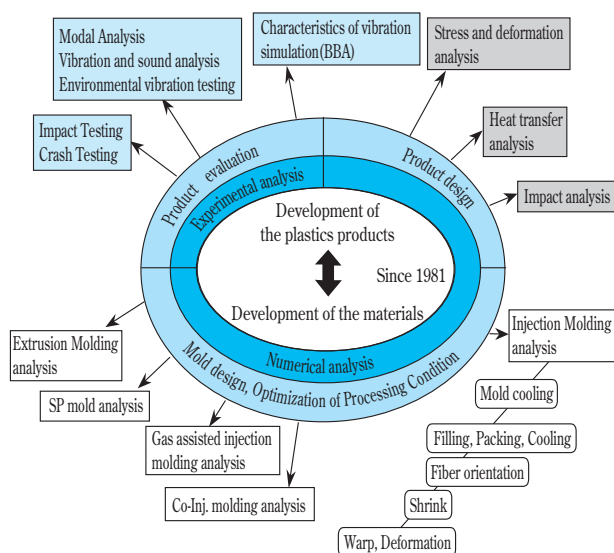

Fig. 1 Plastic-CAE System in Sumitomo Chemical

CAO Technology and Optimal Design

The start for investigations into optimization combining CAE analysis software that uses the finite element

method, which is now the main current for optimal design and investigations, and other methods and optimization software was in investigations for reducing the weight of automobiles in the 1980s.⁹⁾ In the more than 20 years since then, there has been progress in both optimization analysis technology and optimization software, and optimal design technology using CAO has made a great deal of progress.

CAO technology is technology for allowing computer software instead of people to carry out CAE analysis, make judgments on the results and automatically perform optimization work until the target performance is obtained, performing the design optimization work that was, in conventional product development, done through a repetition of human judgments and manual corrections, analysis and evaluation of analytical models until the target performance was obtained using CAE technology for virtual prototyping, carrying out virtual tests and evaluating the results. Furthermore, by integrating various types of CAE, optimization of multiple combined areas necessary when there is integrated optimization of performance in actual products is possible.¹⁰⁾ **Fig. 2** shows a this concept.

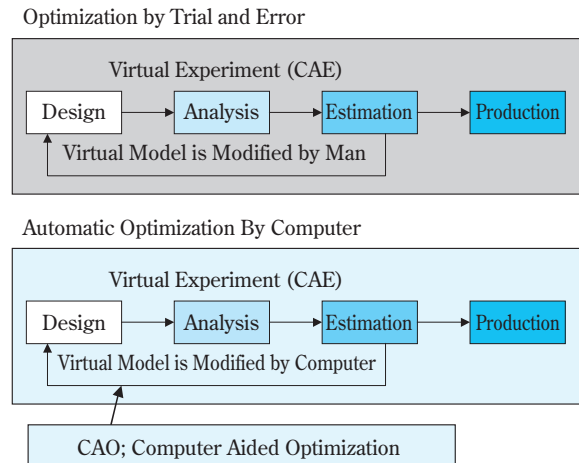

Fig. 2 Comparison of CAE Approach and CAO Approach in a Product Design

1. Optimal Design Problems^{11), 12)}

In general, optimization problems can usually be formulated as mathematical models for finding decision variables such that a function representing a gauge of what is called the objective function is minimized or maximized based on the constraints given.

Optimal design problems are generally made up of the objective function, constraints and design variables (decision variables) and are formulated as follows.

Objective function : $f(\vec{x}) \rightarrow \min$ (1)

Constraints : $g_j(\vec{x}) \leq 0 \ (j = 1 \sim m)$ (2)

$h_k(\vec{x}) = 0 \ (k = 1 \sim m')$ (3)

$\vec{x}^L \leq \vec{x} \leq \vec{x}^U$ (4)

Design variable : $\vec{x} = \{x_1, x_2, \dots, x_n\}^T$ (5)

In this instance, the problem is defined as determining the design variable in equation (5) such that the objective function in equation (1) is minimized while satisfying the constraints in equations (2) – (4). n is the number of design variables; m is the number of inequality equations for the constraints, and m' is the number of integrated constraint equations. The problem above becomes a maximization problem if the objective function is multiplied by (-), and it can be thought of as reversing the orientation of the inequalities if the constraint inequalities are multiplied by (-).

The classifications for the objective functions, con-

straints and design variables that make up optimal design problems are given in **Table 1**.

2. Types of Optimization Methods^{13), 14)}

When optimization is carried out, the characteristics of the target of optimization, the type of design variables and objective function and time required for optimization must be considered. Specifically, when, for example, (1) there is a nonlinear solution space in the optimization, we can bring up questions such as: does it have multiple peaks or a single peak? (2) Are the design variables handled as being continuous or as discrete values or handled as symbols? (3) What kinds of constraints will be set? (4) Is there a single or multiple target performances? (5) Are quality engineering concepts reflected in the target performance? (6) How much time will be needed to run each analysis?

Optimization methods can be generally classified into numerical optimization techniques and exploratory techniques. **Table 2** gives optimization methods classified according to application. Moreover, among the optimization methods in Table 2, simulated annealing and the genetic algorithm are exploratory techniques, and the others are numerical optimization techniques.

The gradient method, which is a numerical optimization technique, can be visualized from **Fig. 3**.

Table 1 Classification of Optimization

Objective Function	Number	Uni-Objective		Multi-Objective
	Type	Functional		Numerical
Constraint Condition	Existence	Constraint		Unconstraint
	Type	Functional		Numerical
Design Variable	Type	Continuous	Discrete	Mixed

Table 2 Optimization Techniques

			Complexity of Objective Function and Constraint Condition		
			Uni-Modal Function		Multi-Modal Function
			Linear Function	Non-Linear Function	
Continuity of Parameter Space	Continuous Parameter	Real	<ul style="list-style-type: none"> • Sequential Linear Programming • Successive Approximation Method • Method of Feasible Directions • Modified Method of Feasible Directions 	<ul style="list-style-type: none"> • Sequential Linear Programming • Sequential Quadratic Programming • Method of Feasible Directions • Modified Method of Feasible Directions • Exterior Penalty • Hooke-Jeeves Direct Search Method • Generalized Reduced Gradient 	<ul style="list-style-type: none"> • Simulated Annealing • Genetic Algorithm • (Successive Approximation Method) • (Mixed Integer Optimization)
		Integer	<ul style="list-style-type: none"> • Hooke-Jeeves Direct Search Method • Successive Approximation Method • Mixed Integer Optimization • Simulated Annealing • (Genetic Algorithm) 		
	Discrete Parameter	Symbol	<ul style="list-style-type: none"> • Simulated Annealing • Genetic Algorithm • (Successive Approximation Method) • (Mixed Integer Optimization) 		

Blue Character : Numerical Optimization Technique

Red Character : Exploratory Technique

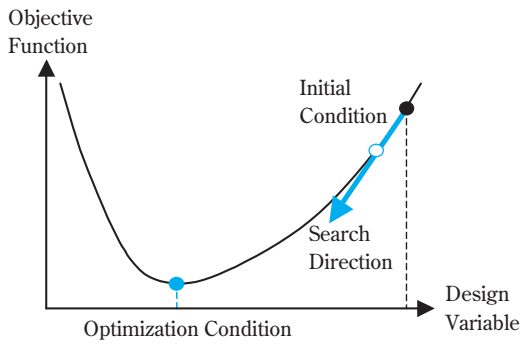

Fig. 3 Schematic Diagram of Numerical Optimization

Numerical optimization techniques are ones that determine the optimal direction from the slope (sensitivity) in the vicinity of the design variable currently being focused on and successively change the design variable. Numerical optimization techniques give well organized optimization solutions when there is an optimization space with a single peak, but when optimizing a multi-peak solution space it often gets trapped locally and cannot give a comprehensive optimization. Therefore, when it is predicted that the target of optimization will have multiple peaks, an exploratory technique is used. Simulated annealing, which is an exploratory technique, can be visualized from **Fig. 4**.

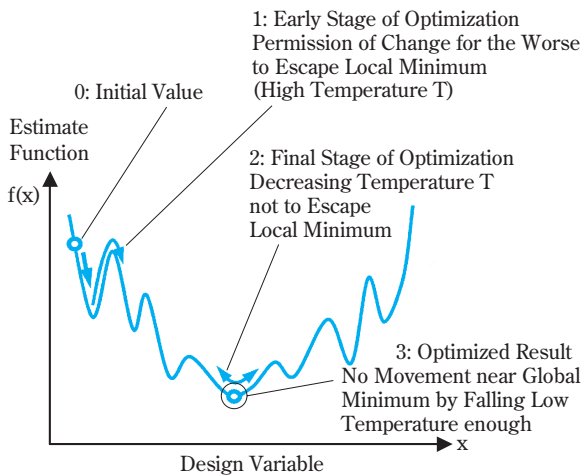

Fig. 4 Schematic Diagram of Simulated Annealing

Simulated annealing is a technique modeled on the physical phenomena when metal is annealed, and it is characterized by permitting deteriorating solutions of a suitable probability while searching for design variables that improve the objective function. Moreover, the probability permitting deterioration in the solution

is made high at the beginning of optimization and low in the final stages to give the optimal solution.

In actual optimizations, the concepts of multipurpose optimization and quality engineering are further combined according to the manner in which the objective function is handled, and from the standpoint of the time required for optimization, there may be combinations with approximation models and the like to carry them out.

Fig. 5 shows the flow for a response surface model that is often used as an approximation model.

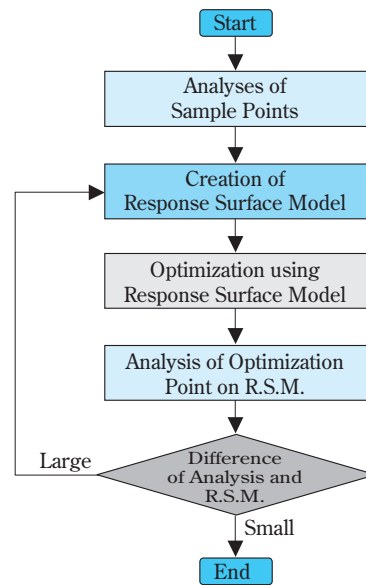

Fig. 5 Flowchart of Response Surface Model (R.S.M.: Response Surface Model)

With a response surface model, solutions are found for several sample points in advance, and a response surface for a quadratic function or the like is found using these. Optimization is carried out on the response surface. If the difference between the analytical solution using the design variables for the optimal solution found and optimal solution for the response surface is not sufficiently small, the optimal solution for the response surface is added to the sample points and the response surface formed once again to carry out the optimization. This operation is repeated until the difference between the analytical solution and the optimal solution for the response surface is sufficiently small.

3. Plastic Product Optimization Design Problems

The performance and quality of plastic products are intertwined in a complex manner with three factors,

the material, the product design and the molding process.⁶⁾ The factor of the material includes mechanical properties, thermal properties and rheological properties. The factor of the product design includes the shape and structure of product. The factor of the molding process includes the mold structure and the molding conditions. At designing products, these three elements must be considered while optimizing the product design. In other words, designing plastic products is a optimization problem with a combination of areas where optimization is carried out while simultaneously considering each of these elements. Conventionally, Sumitomo Chemical used the CAE system in Fig. 1, repeating the processes of analyzing, evaluating and correcting.

The commercial CAO support software “iSIGHT” (Engineous Software, Inc., U.S.A.), which has an optimization function for combined areas was developed in the United States in 1994, and it entered the Japanese market at the end of 1998.³⁾ Sumitomo Chemical confirmed that this software would be effective for plastic product optimal design problems in early testing and introduced it in 2000. After that, investigations into integration technology for conventionally constructed CAE technology and CAO technology were carried out for making progress toward a second generation plastic CAE technology.

At present, automated optimization technology has been established for the principle CAE technologies, and in addition, automatic optimization technology for integrating these CAE technologies with combinations of areas has been established. To further increase the efficiency and simplify this optimization work, we are

currently developing the Sumika Integrated Design Optimization System for Plastic Products (SIDOS) where optimization work can be done on a graphical user interface (GUI) without specialized CAO knowledge.

Fig. 6 shows a schematic of SIDOS.

Examples of Applying CAO Technology to Plastic Product Design

The application of CAO techniques to plastic product design is roughly divided into cases of application to the structural aspects of products to obtain the optimal performance for the functions (rigidity, impact absorption characteristics, vibration characteristics, etc.) required for the plastic product and cases of application to the optimization of mold structure design and molding conditions so that the necessary quality is achieved in molding aspects and constraints (clamping force, cycle time, etc.) for molding for plastic products having designs defined in terms of the structural aspects.

The following two points can be raised as important points for application of CAO techniques in actual product design. One is how to extract the design variables for design items in the target of optimization and the other is how to digitalize the performance for the target of optimization and set the objective function. In the following we will introduce applications to plastic product design with regard to these two points in examples. The various solvers shown in Fig. 6 are used in the CAE analysis in these examples.

1. Application of Optimization Techniques to the Design of Parts for Automobile Interiors

(1) Impact absorption performance required for interior parts for automobiles.

Plastic products for the interior parts in automobiles require freedom of shape and have be multipurpose in terms of weight and cost on the one hand, and must maintain a sufficient shock absorption performance for secondary impact (impact inside of the car) with the heads of passengers during accidents. For example, in the standards in Federal Motor Vehicle Safety Standard (FMVSS) 201U provided by the National Highway Traffic Safety Administration (NHTSA), the head part in the parts shown in Fig. 7, must have sufficient shock absorption performance so that no injury will be caused even with secondary impact to the head.¹⁵⁾

In evaluations of shock absorption performance for

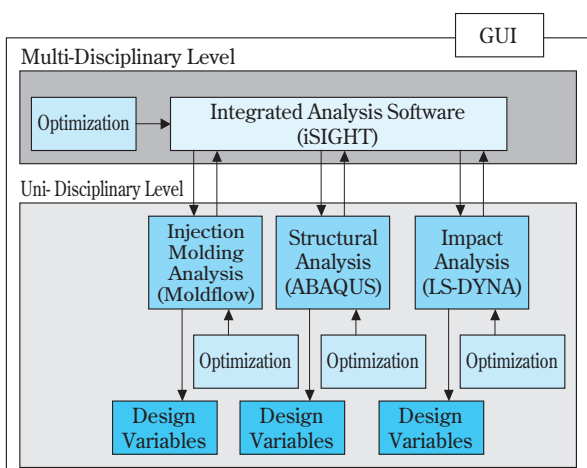

Fig. 6 SUMIKA Integrated Design Optimization System for Plastic Product (SIDOS)

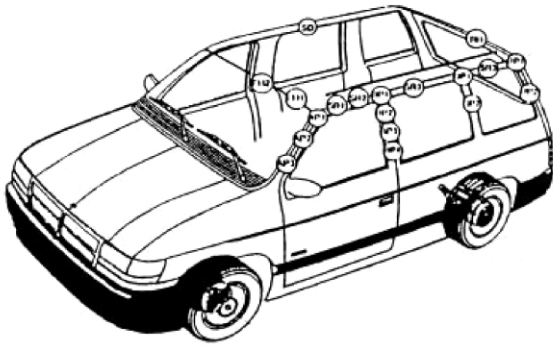

Fig. 7 Typical Target Location of Interior Parts for FMVSS201U

FMVSS201U, there is impact with a 4.54kg free motion headform (FMH: crash dummy head) at a velocity of 6.7m/s from the direction of the head position when people are seated, with the interior parts that are the target attached to the automobile body, and this is done using *HIC (d)*, calculated using equation (6) and equation (7) from the total acceleration $a(t)$ measured at the center of gravity for the FMH during the impact and a time function.^{16) - 18)} (**Fig. 8**)

$$HIC = Max [(t_2 - t_1) \{ \frac{1}{t_2 - t_1} \int_{t_1}^{t_2} a(t) dt \}^{2.5}] \quad (6)$$

(where $t_2 - t_1 \leq 36m \text{ sec}$)

$$HIC(d) = HIC \times 0.75446 + 166.4 \quad (7)$$

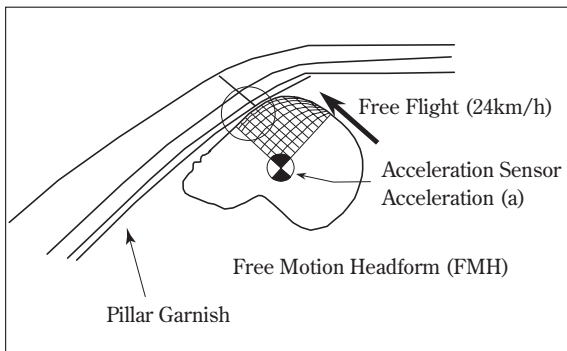

Fig. 8 Method of Impact Test (FMVSS201U)

(2) Structural Optimization

As one method for achieving the shock energy absorption function at the time of impact in plastic parts that require shock absorption performance, the use of a ribbed structural body attached to the back side of the part is common. The overall rigidity of the part and the deformation behavior (displacement and load) can be designed such that the necessary shock absorption function is obtained by adjusting the thickness of the rib parts, their position and the rib pitch.^{16), 18)}

When we choose the rib pitch as the design variable for this type of rib structure, the number of ribs is increased or decreased according to modifications in the rib pitch, and the topology of the shape model is changed. On the other hand, even if we attempt to use the commonly used phase optimization technique, (1) the stress and strain energy is limited in a structural analysis where the objective function is static, and complex values obtained from a dynamic analysis, such as *HIC (d)*, cannot be selected; (2) it is actually impossible to apply this to the rib structural body in this example because of such aspects as not being able to optimize the shape according to the rules since the phase optimization technique removes any part of the part.¹⁹⁾

For the ribbed structure for interior automobile parts, automated optimal design is possible using the macro function in modeling software. Specifically, a macro program for creating the rib structure for one rib space is prepared, and a ribbed structure composed of any number of ribs can be created automatically just by repeating this the necessary number of times for forming the structure.

The process ((1) reading standard model, (2) creating a vertical rib at the standard position, (3) creating a vertical rib at a position offset by one pitch length, (4) creating a horizontal rib at the standard position, (5) creating a horizontal rib a position offset by one pitch length, (6) defining the rib connection conditions

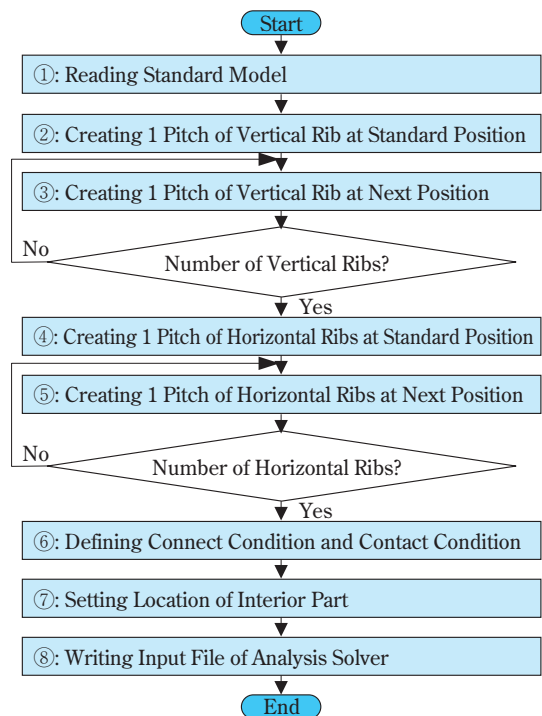

Fig. 9 Flowchart of Creating Analysis Model

and contact conditions, (7) setting the position of the interior parts and FMH flow and (8) saving the analysis input file) flow for the automatic modeling carried out in the optimal design in this example is shown in Fig. 9.^{20), 21)}

Table 3 gives the material characteristics for three types of shock resistant polypropylene. The material strain rate dependency has been considered in the application of the Cowper-Smyonds equation shown in equation (8) to yield stress.

Table 3 Material Properties

Materials		A	B	C
Young's Modulus	[MPa]	863	2420	863
Specific Gravity	[-]	0.90	1.08	0.90
Poisson Ratio	[-]	0.40	0.40	0.40
Static Yield Stress	[MPa]	19.6	23.9	19.6
Failure Plastic Strain	[%]	40.0	8.0	8.0
Cowper-Symonds Parameter				
C	[1/s]	2.80	170	2.80
P	[-]	9.87	4.56	9.87

$$\sigma_y = \sigma_{y0} \times \left[1 + \left(\frac{\dot{\epsilon}}{C} \right)^{\frac{1}{P}} \right] \quad (8)$$

σ_y : yield stress, σ_{y0} : static yield stress,
 $\dot{\epsilon}$: strain rate, C, P : parameters

The vertical rib positions (vertically oriented ribs in Fig. 10) and horizontal rib positions (horizontally oriented ribs in Fig. 10) and rib pitch for the rib parts were selected as the design targets. Therefore, there were a total of five design variables, three variables for the design prescribing the vertical ribs, the y coordinates (T1 and T2) for the starting point and end point for the line segment in the design range on a line formed in the xy plane which is the plane that includes

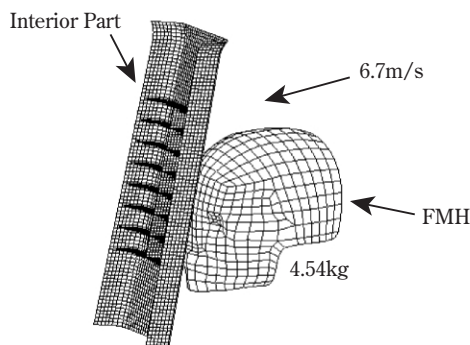

Fig. 10 Simulation Model of FMH and Interior Part

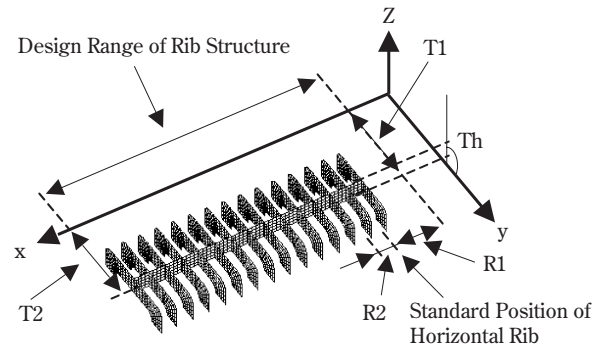

Fig. 11 Design Variables of Rib Structure

the vertical rib and the angle (Th) with the y axis for the yz plane that includes the vertical rib, and two variables for the design that prescribes the horizontal ribs, the distance (R1) in the x direction between the standard position for the horizontal rib and the part parallel to the yz plane in the design range and the distance (R2) between horizontal ribs. (Fig. 11)

In addition, the objective function is HIC (d) calculated using equation (1), equation (2) and the acceleration at the FMH center of gravity for the analysis model. A combination of the response surface model and modified method of feasible directions was used for the optimization method.

As results in this example, it was found that interior parts with the rib shape optimized using material B with a large Young's Modulus and yield stress and a small failure plastic strain exhibited the most superior shock absorption performance. The initial shape for the material B interior parts had a HIC (d) that exceeded 1000, but as a result of optimizing the rib shape, with the pitch of the horizontal ribs being reduced and the position of the vertical rib brought closer to the FMH impact position, HIC (d) was reduced to under 600, and the performance was improved. (Fig. 12)

Material A	Material B	Material C

Fig. 12 Results of Optimization

2. Application of Optimization Techniques to the Design of Metal Molds for Injection Molding

(1) Controlling Weld Locations

Currently, most of the automotive, consumer electronics and other plastic parts are formed using injection molding, but the large parts among these mostly have metal mold designs that arrange multipoint gates from the standpoint of reducing the clamping force. In addition, there are frequently openings in plastic parts due to the aspects of product function and design. The flow of plastic injected through gates other than the multipoint gates of this type and the flow of plastic separated by the openings in it bring about a linear unevenness that is called a weld line in that part where they flow together. (Fig. 13)

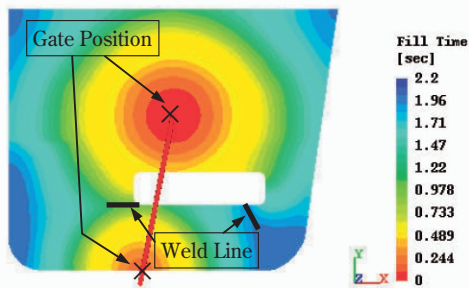

Fig. 13 Flow Pattern and Weld Line

These weld lines are not only handled as a failure phenomenon in terms of appearance, but since there is deterioration in mechanical strength in the parts where the flows come together, gate runners are designed to either eliminate them as much as possible or make them occur in parts where the effect will be the least.

When the gate runners are designed using CAE to prevent weld lines or make them occur in target positions, the situation in occurrences is normally judged through visual observation, but to use CAO techniques for automated design, the situation in the occurrence of weld lines must be digitalized and set up as the objective function.

In this example the areas of weld line occurrences are divided up, and digitalization is possible by weighting each area.

The plastic part used in the investigation is a flat plate that has an opening in the center, with a width of 1000 mm a length of 800 mm and a thickness distribution of 2.0mm – 3.5mm. In addition, there are gates at two points, the center and the side. (Fig. 14)

The material used for molding the plastic parts is

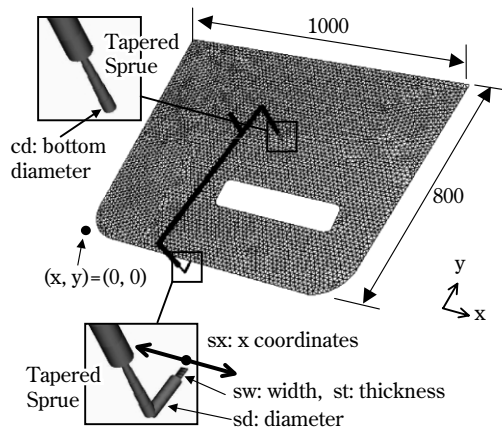

Fig. 14 Simulation Model of Plastic Part

polypropylene with MFR=30 (g/10 min, 230°C), and the molding conditions are a plastic temperature/metal mold temperature of 210°C/40°C, with an injection time of 2 seconds.

In this example, the position of the center gate is fixed, and the design targets are the side gate positions and the dimensions of each of the gates. Specifically, there are five design variables, the x coordinate s_x for the position of the side gate, the land width sw , the land thickness st , the runner diameter sd and the gate diameter cd for the center gate. (Fig. 14)

In this example, the goal was designing a mold that can reduce the mold clamping force while holding the weld line to a prescribed position, and the objective function was the linear sum of mold clamping force obtained from the injection molding analysis and the weld evaluation value calculated from the position in which the weld occurs. This weld evaluation value is defined as the sum total of the products of the weighted coefficient set for each of the areas 1 – 20 shown in Fig. 15 and the number of welds detected in each area.

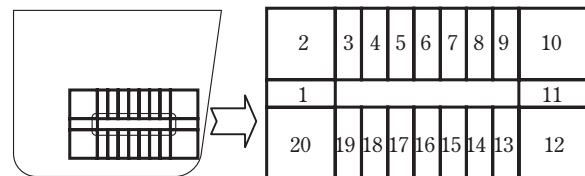
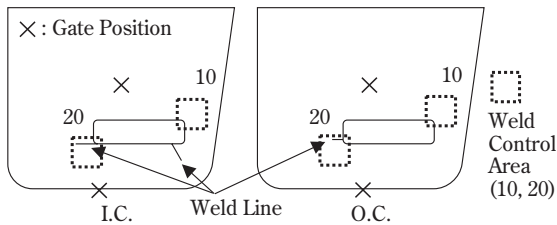

Fig. 15 Definition of Areas for Weld Evaluation

The weighted coefficient is given in steps of coefficients from 1 – 2500 for each area where the coefficient for areas (10, 20) where we want the welds to occur is 1, and the coefficient for the areas (5, 15) furthest from these areas is 2500. ^{23), 24)}

In this example, the side gate is moved approximately 70mm toward the right side with almost no change in the dimensions of the center gate, and by increasing each of the dimensions for the side gate, results where it was possible to have no welds occur outside of areas 10 and 20 and to reduce the clamping force to 60% or less of the initial value were obtained. (Fig. 16, Table 4)



(I.C.: Initial Condition, O.C.: Optimized Condition)

Fig. 16 Comparison of the Result Before and After Optimization

Table 4 Comparison of the Result Before and After Optimization

		I.C.	O.C.
sx	[mm]	400	471
sw	[mm]	5.0	7.5
st	[mm]	1.0	1.7
sd	[mm]	8.0	11.0
cd	[mm]	8.0	8.1
clamp	[ton]	1532	857
weld	[-]	10008	4
obj.	[-]	11540	861

clamp : Value of Clamping Force
 weld : Value of Weld Evaluation
 obj. : Value of Objective Function
 I.C. : Initial Condition
 O.C. : Optimized Condition

Moreover, optimization proceeded to change the design variable in the direction that moved the right weld line into area 10 while keeping the weld line that occurred on the left side under the initial conditions in area 20 where it was. And the right weld line disappeared in the middle of the optimization process.

(2) Reduction of Warp and Deformation

Depending on the molding conditions, plastic parts molded using injection molding may deviate greatly from the dimensions of the metal mold due to the occurrence of deformation and warping after being removed from the mold. As a countermeasure for this, it is known that it may be sufficient to, for example,

increase the cooling time, but on the other hand, this increases the molding cycle time and reduces productivity. Here, we will introduce an example where CAO techniques are applied to optimization of molding conditions for these kinds of diametrically opposed requirements.

The shape model for the plastic part in this example is shown in Fig. 17 and the mold cooling tubes in Fig. 18.

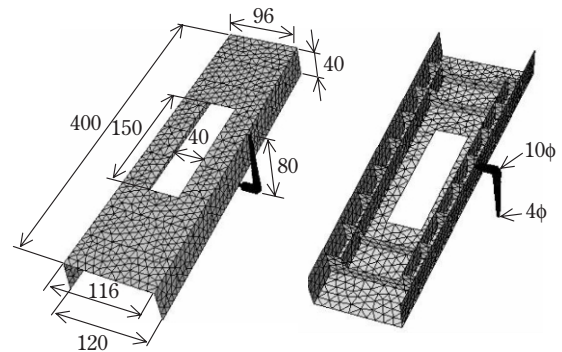

Fig. 17 Simulation Model of Plastic Part

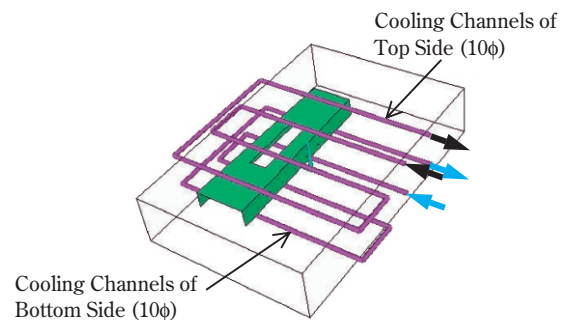
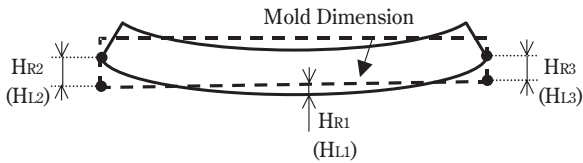

Fig. 18 Cooling System of Injection Mold

A MFR=30 (g/10 min, 230°C) polypropylene resin was used for the molding material. Among the molding conditions, the resin temperature M_T , the fixed top/bottom side mold cooling water temperatures W_{T1}/W_{T2} and the pressurization time P_r are set for the design variables. Other molding conditions were the injection time set to 3 seconds, the holding pressure applied set to 80% of the maximum injection pressure and the surface temperature for the molded product when removed set to 75°C. Moreover, the cooling time was determined such that the surface temperature of the molded product reached 75°C after the resin hardening rate was 100%.

The objective function was the linear sum $3(D/D_0) + (T/T_0)$, where D was a sum of warp in the direction of

mold removal on the gate side surface and the opposite gate side surface and T was a cycle time (D₀ and T₀ being the initial values). Moreover, to give the reduction in warp priority in this example, this was carried out with the sum of the warp being given a weighting of 3 times that of the molding cycle.



Total Warpage : $D = HR + HL$
 Gate Side : $HR = HR1 + \max(HR2, HR3)$
 Opposite Side of Gate: $HL = HL1 + \max(HL2, HL3)$

Fig. 19 Definition of Total Warpage

Compared with the initial conditions, the resin temperature and fixed side cooling temperature were reduced, the cooling temperature on the mobile side increased, the time pressure was maintained increased, and the results obtained were an approximately 40% reduction in warp and a 15% shortening of the molding cycle. (**Fig. 20, Table 5**)

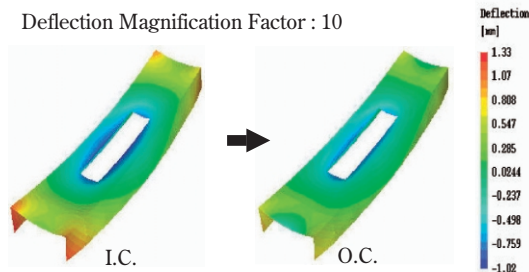

(I.C. : Initial Condition, O.C. : Optimized Condition)

Fig. 20 Comparison of the Result Before and After Optimization

Table 5 Comparison of the Result Before and After Optimization

		I.C.	O.C.
M _T	[°C]	220	210
W _{T1}	[°C]	40	21
W _{T2}	[°C]	40	49
P _r	[sec]	6.0	7.8
D	[mm]	2.9	1.8
T	[sec]	48.1	40.7
obj.	[-]	4.0	2.7

obj. : Value of Objective Function
 I.C. : Initial Condition
 O.C. : Optimized Condition

3. Optimization Technique for Combined Performance of Structure and Molding for Injection Molding

The examples introduced up to this point have evaluated a single type of analysis (impact analysis or injection molding analysis) for the design target performance, but with real products, the structure must be determined by evaluating the integrated performance of products for multiple types of analysis. Here, we will introduce an example of optimal design for three types of performance, impact performance, product rigidity and molding characteristics for a pillar B interior automobile part. Impact performance is evaluated using HIC (d) obtained from the impact analysis, and when a negative load of 100N is applied at a midpoint in the attached part, the product rigidity is evaluated using the values obtained from a structural analysis of the changes in position; the molding characteristics are evaluated using the clamping force obtained from the injection molding analysis. Moreover, in terms of the precision of the analysis, the shape models for the impact analysis and structural analysis use square elements and the shape model for the injection molding analysis uses triangular elements. (**Fig. 21**)

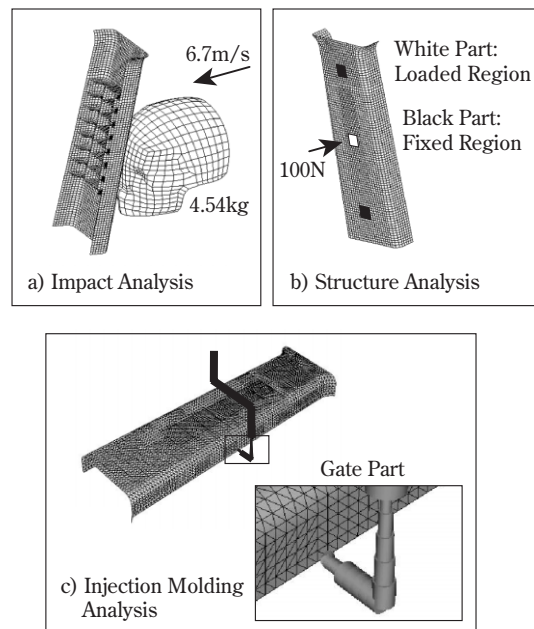

Fig. 21 Simulation Models

For design variables in the present example, we used the standard position (R1) for the horizontal rib and the rib pitch (R2), and the objective function was the linear sum of HIC (d) value H, the deformation D when

the negative load was applied and the clamping force C during injection molding.

Moreover, it was made dimensionless with H being the critical value 1000, D being 1/10 of the pillar thickness or 3mm, and C being the maximum clamping force for the presumed molding machine or 50 tons.

The results of optimization were that the rib pitch was narrowed, HIC (d) reduced, and the rigidity improved somewhat. (Table 6)

Table 6 Comparison of the Result Before and After Optimization

		I.C.	O.C.
R1	[mm]	10.0	14.2
R2	[mm]	50.0	29.7
H	[-]	956	737
D	[mm]	1.59	1.25
C	[ton]	28.4	28.2
obj.	[-]	2.06	1.72

obj. : Value of Objective Function
 I.C. : Initial Condition
 O.C.: Optimized Condition

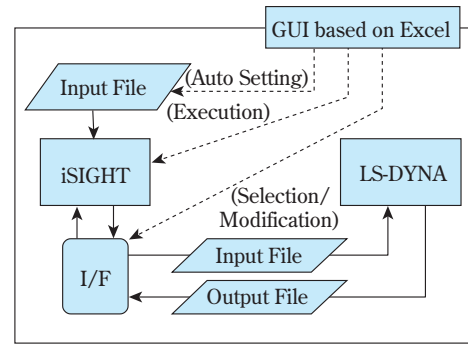

Fig. 22 Schematic Diagram of System

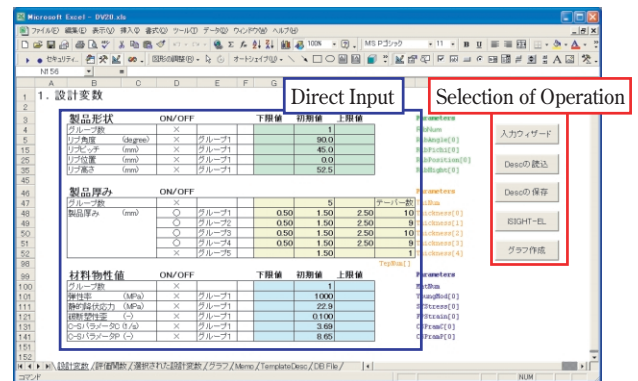

Fig. 23 Input Form of Design Variables

4. Work on Sumika Integrated Design Optimization System for Plastic Products (SIDOS)

In the examples of CAO technique applications that have been discussed so far, not only have the design variables, objective functions, constraints and optimization techniques been set, but also it has been necessary for the data from the optimization support software and CAE software to be passed on and reflected in the design variable analysis model, the analytical results digitalized and the interface (I/F) for constructing the objective function and the like established.

Therefore, we are developing the Sumika Integrated Design Optimization System for Plastic Products (SIDOS) so that when this technology is applied to actual work, we not conscious of these settings, and it is possible to carry out optimization calculations simply and easily. Out of this, we will introduce a system that combines the optimization support software iSIGHT and impact analysis software LS-DYNA to bear the burden of the single area optimization function here.

This system is based on Excel on a PC and is shown in Fig. 22; the goal is being able to perform optimization functions simply by automatically making settings for the items to be set for optimization

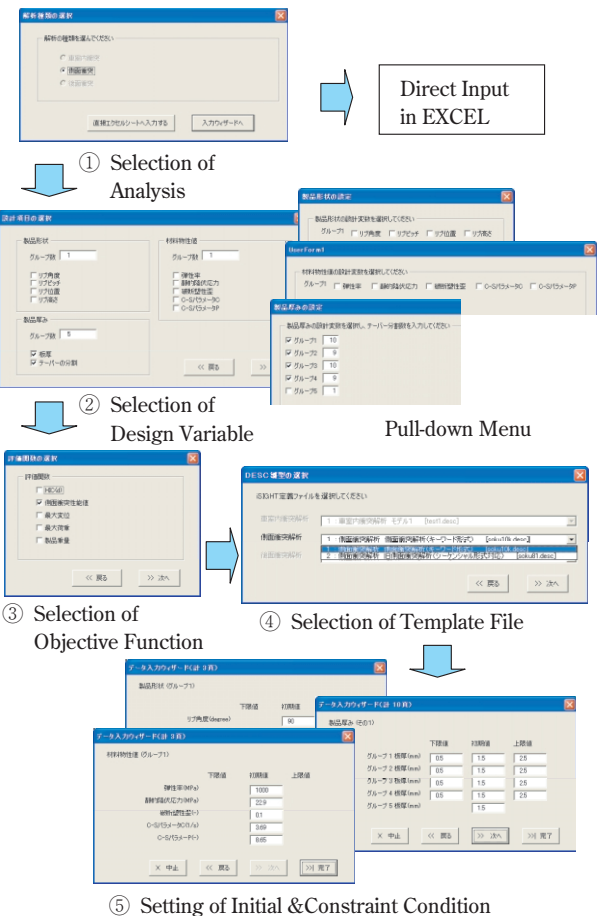

Fig. 24 Flow of Setting for Optimization

in the input iSIGHT file, and selecting the necessary I/F in the I/F part or modifying the standard I/F. In addition, after the settings for optimization and the I/F settings are complete, it is possible to carry out optimization calculations directly from this system.

The input screen from Excel is shown in **Fig. 23**. The design variables are selected with an O or X from the product shapes, product thicknesses and material characteristics shown in the cells, and the constraints (lower limit value / upper limit value) and the initial conditions can be set for each.

In addition, an input wizard is launched from the in the upper right part of the screen, and each of the settings can be made according to the flow shown in **Fig. 24**.

Conclusion

At present, plastic CAE is used as an essential technology in for plastic products and product development. However, by integrating this technology and CAO technology, we get an even more powerful product design technology and move from the second generation technology to the third generation technology. The time of the optimization of the material properties that satisfy product specifications (reverse design) was required with the second generation technology. Using CAO technology, it is possible to increase the speed for the optimization. And the optimization is an effective support technology for materials development. In addition, even though it was omitted from this paper, it is possible to simultaneously optimize product structure and material characteristics, and it has become possible to improve product quality and performance even further.^{25), 26)} The third generation technology is essential technology for the fourth generation technology (technology for predicting product properties from the polymer structure through the properties of the material, and conversely, for predicting the optimal polymer structure from the product properties by integrating the third generation technology and polymer material design CAE technology) that should come along.

Along with lateral developments of the third generation technology discussed in this paper, the authors plan to move forward with the development of the fourth generation technology along with mak-

ing progress in giving this technology more depth and making it even more complete.

References

- 1) P. Y. Papalamos and D. J. Wide: "Principles of Optimal Design", Cambridge University Press, 40-42 (2000)
- 2) Nikkei Mechanical (Japanese): 1994.6.27, P36
- 3) CAO Frontier '99 Proceedings (Japanese): Engineous Japan Inc. (1999.11.30)
- 4) T. Aizawa and Y. Maekawa, ed.: "CAE Shinseihin Kaihatsu Sekkei Shien Konpyuta tsuru (CAE Computer Tool for Development and Design of New Products)", Kyouritsu Syuppan, 2 (1998)
- 5) S. Masui, Y. Togawa, T. Sakai, T. Kikuchi and N. Usui: SUMITOMO KAGAKU, 1984-II, 70-86 (1984)
- 6) M. Nagata, T. Kikuchi, Y. Nakamura, Y. Togawa and T. Hara: SUMITOMO KAGAKU, 1992-II, 68-86 (1992)
- 7) Y. Togawa, K. Higashi, M. Tsutsubuchi, T. Kayanoki and M. Shimojou: SUMITOMO KAGAKU, 1995-I, 75-86 (1995)
- 8) S. Nagano, H. Yamauchi and M. Hirakawa: SUMITOMO KAGAKU, 2001-II, 13-19 (2001)
- 9) H. Yamakawa, ed.: "Saiteki Sekkei Handobukku (Optimal Design Handbook)", Asakura Syoten, 297 (2003)
- 10) H. Yamakawa, ed.: "Saiteki Sekkei Handobukku (Optimal Design Handbook)", Asakura Syoten, 80 (2003)
- 11) T. Ibaraki and M. Fukushima: "Saitekika No Shyuhou (Techniques of Optimization)", Kyouritsu Syuppan, 1 (1998)
- 12) H. Yamakawa, ed.: "Saiteki Sekkei Handobukku (Optimal Design Handbook)", Asakura Syoten, 6-7 (2003)
- 13) iSIGHT Version 6.0 Reference Guide, Engineous Software, Inc., June 2001
- 14) CAO Campus iSIGHT Middle Course Text (Japanese): Engineous Japan Inc. (2002.3)
- 15) Helen A. Rychlewski, Jessica A. Cronkhite and Michael J. Smith: SAE Paper No. 1999-01-0434 (1999)
- 16) Gajanan V. Gandhe and Louis Lorenzo, Yoshinori Noritake: SAE paper No.970161 (1997)
- 17) Takahiro Kondou and Tuyoshi Yasuki: 2005 JSAE Annual Congress Technical Papers No.31-

- 99 pp.13–16 (1999)
- 18) James M. Lorenzo: SAE Paper No. 1999-01-0433 (1999)
- 19) Yoshiaki Togawa, Tomoo Hirota, Touru Yabe and Masaaki Tsutsubuchi: JSPP '00 Symposium Papers, 11 (2000)
- 20) Yoshiaki Togawa and Tomoo Hirota: JSPP '02 Technical Papers, 151 (2002)
- 21) Yoshiaki Togawa and Tomoo Hirota: Proceedings of the 8th Japan International SAMPE Symposium, 613–616 (2003)
- 22) Yoshiaki Togawa, Tomoo Hirota, Makoto Naga-
ta and Touru Yabe: JSPP '01 Technical Papers, 35 (2001)
- 23) Yoshiaki Togawa and Tomoo Hirota: JSPP '03 Technical Papers, 331 (2003)
- 24) Shinichi Nagaoka, Tomoo Hirota and Yoshiaki Togawa: SPE ANTEC 2004, Conference Proceedings, 3438–3442 (2004)
- 25) Yoshiaki Togawa and Tomoo Hirota: JSPP '02 Symposium Papers, 263 (2002)
- 26) Tomoo Hirota and Yoshiaki Togawa: SPE ANTEC 2002, Conference Proceedings, 2578–2581 (2002)

PROFILE

Yoshiaki TOGAWA
Sumitomo Chemical Co., Ltd.
Petrochemicals Research Laboratory
Research Fellow



Shinichi NAGAOKA
Sumitomo Chemical Co., Ltd.
Petrochemicals Research Laboratory



Tomoo HIROTA
Sumitomo Chemical Co., Ltd.
Petrochemicals Research Laboratory
Research Associate